



MERCEDES BENZ

SPRINTER

210 CDI / 214 CDI / 310 CDI / 314 CDI / 510 CDI / 213 CDI / 313 CDI /
413 CDI / 513 CDI / 216 CDI / 316 CDI / 416 CDI / 514 CDI / 516 CDI
BLUETEC E6

CODE / CODICE: 0500.8542

**COMPRESSOR / COMPRESSEUR /
KOMPRESSOR / COMPRESSORE / COMPRESOR :**

**SELTEC: TM13 / 15 / 16
QUE: QP13 / 15 / 16**

FITTING INSTRUCTIONS

**EINBAUANLEITUNGEN
INSTRUCTIONS POUR LE MONTAGE
ISTRUZIONI DI MONTAGGIO
INSTRUCCIONES DE MONTAJE**

Contents

ENGLISH	4
Parts View.....	4
Parts List	5
Compressor Configurations	6
Standard Fastener Torque Values	6
Kit Details	7
Vehicle Details	7
Forward	7
Pre Installation.....	8
Compressor Installation.....	8
Drive Belt Installation	9
Post Installation.....	9

PARTS VIEW / VUE ÉCLATÉE / TEILEANSICHT / VISTA PARTA / IMÁGENES DE LAS PIEZAS

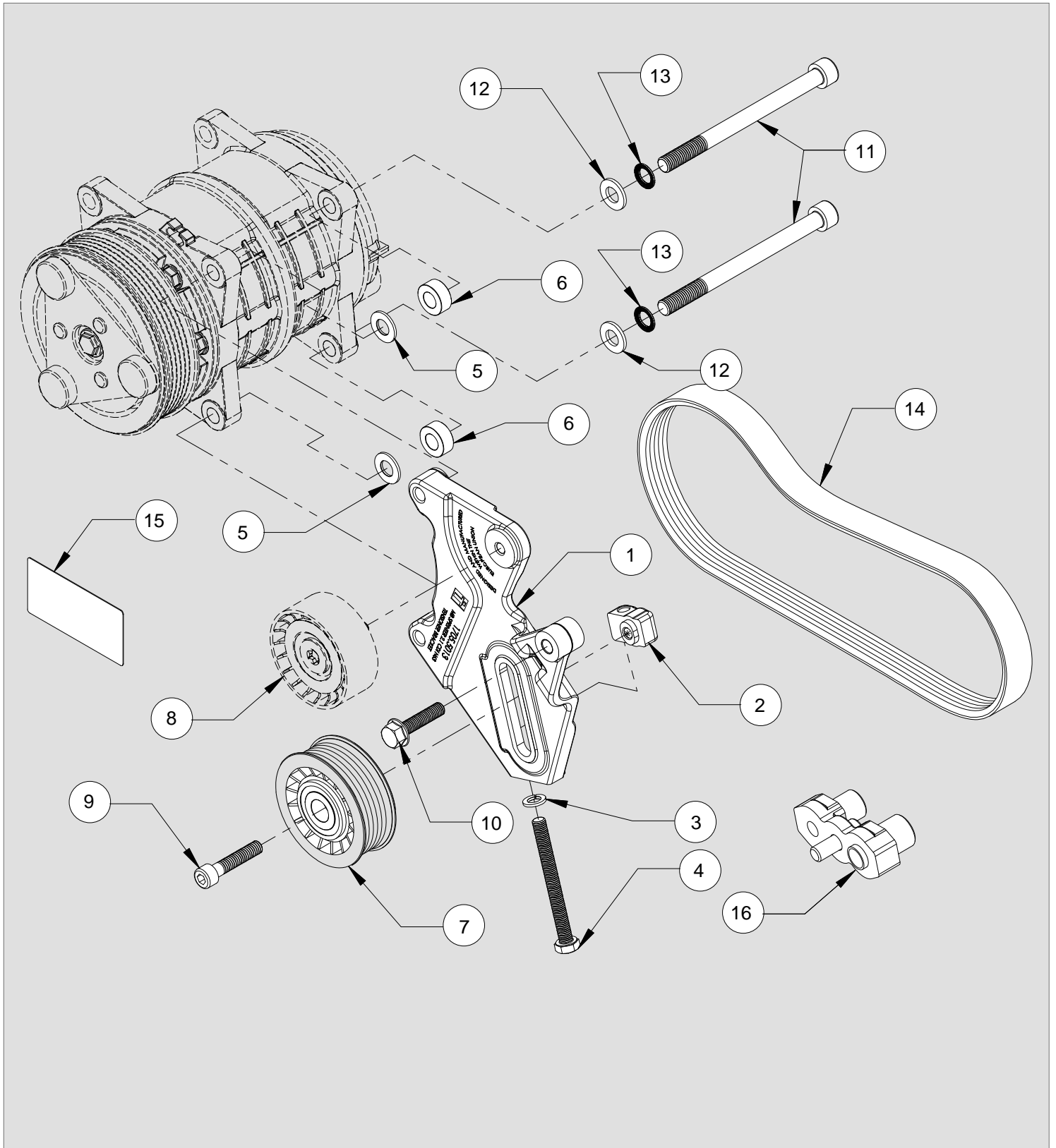

PARTS LIST / NOMENCLATURE / TEILELISTE / ELENCO DELLE PARTI / LISTA DE PIEZAS

ITEM	CODE / CODICE / KODE / CODIGO	DESCRIPTION / DESCRIZIONE / BESCHREIBUNG / DESCRIPCION	QTY.	COMMENTS
1	1705.5013	Idle Pulley Bracket	1	-
2	1703.5003	Idle Pulley Adjuster	1	-
3	2808.0031	Spring washer M8 x 1.6 -ID 8.3 OD 14.0	1	-
4	2719.0081	Hex Set Screw - M8 x 80 : 1.25 - 8.8	1	-
5	2803.9023	Shim 20.00 OD x 10.50 ID x 1.60	2	-
6	2803.9013	Spacer - 20.00 OD x 10.40 ID x 8.40	2	-
7	1700.5021	Idle Pulley 6PK x 75 Dia	1	-
8	1700.0641	Idle Pulley - Original	1	Original O.E
9	2704.0021	Hex socket head cap screw M8 x 40 : 1.25 - 12.9	1	-
10	2704.0481	Hex flange bolt Durlok - M8 x 35 : 1.25 - 12.9	1	-
11	2705.0301	Hex socket head cap screw M10 x 130 : 1.50 - 12.9	2	-
12	2809.0011	Washer M10 Flat Steel DIN 125 A 10.5	2	-
13	2809.0101	M10 Schnorr Safety Washer Type 'S'	2	-
14	0820.2241	Belt Poly Groove 6PK 1250	1	-
15	2902.4072	Belt Label	1	-
16	0425.0511	Manifold - ST 3/4 x 7/8	1	-

**COMPATIBLE COMPRESSORS / COMPRESSEURS RECOMMANDÉS / EMPFOHLENE KOMPRESSOREN
RACCOMANDATO COMPRESSORI / RECOMENDADAS COMPRESORES**

SELTEC	QP13-HD	QP15-HD	QP16-HD
Comp No	0391.0202	0391.0002	0391.0312
Valeo No.	QP15-1302	QP15-1171	QP16-1581
Mounting	Ear	Ear	Ear
Rotor	8PV	8PV	8PV
GL	SL	SL	SL
Armature	123	123	123
Diameter	12	12	12
Voltage	H (P)	H (P)	H (P)
Orientation	3/4 x 7/8	3/4 x 7/8	3/4 x 7/8
Fitting	Bolt	Bolt	Bolt
Manifold	-	-	-

QUE	TM-13 HS	TM15-HS	TM16-HS
Comp No	0381.0202	0381.0002	0381.0312
Que No.	488-45120	488-45120	488-46134
Mounting	Ear	Ear	Ear
Rotor	8PV	8PV	8PV
GL	SL	SL	SL
Armature	123	123	123
Diameter	12	12	12
Voltage	H (P)	H (P)	H (P)
Orientation	3/4 x 7/8	3/4 x 7/8	3/4 x 7/8
Fitting	Bolt	Bolt	Bolt
Manifold	-	-	-

SANDEN	-	-	-
Comp No	-	-	-
Sanden No.	-	-	-
Mounting	-	-	-
Rotor	-	-	-
GL	-	-	-
Armature	-	-	-
Diameter	-	-	-
Voltage	-	-	-
Orientation	-	-	-
Fitting	-	-	-

NOTES

STANDARD FASTENER TORQUE VALUES

In the absence of specific torque values detailed in this fitting instruction manual, the following chart can be used as a guide to the maximum safe torque for specific size and grade of fastener.

COUPLES DE SERRAGE DES FIXATIONS STANDARDS

Si des chiffres de serrage au couple particuliers ne sont pas indiqués dans cette notice de montage, se référer au tableau suivant qui servira de guide pour le couple de sécurité maximum correspondant à une taille et un grade spécifiques de fixation.

ANZIEHMOMENTE FÜR STANDARDBEFESTIGUNGSMITTEL





Falls in dieser Einbauanleitung keine speziellen Anziehmomente angegeben sind, kann die folgende Tabelle als Richtlinie für das maximale sichere Anziehmoment für eine spezifische Größe oder Qualität von Befestigungsmitteln dienen.

VALORI STANDARD DI SERRAGGIO PER DISPOSITIVI DI FISSAGGIO

In assenza di valori specifici di coppia nel presente manuale di istruzioni, si può utilizzare la seguente tabella come guida per conoscere la coppia massima sicura in base a dimensioni e grado del dispositivo di fissaggio.

VALORES ESTÁNDAR DE LOS PARES DE APRIETE Y FIJACIÓN

En ausencia de valores para los pares de apriete específicos detallados en este manual de instrucciones de montaje, se puede utilizar la siguiente tabla como guía para consultar el máximo par de torsión seguro para un tamaño concreto y su grado de fijación.

STRENGTH								
	Max Torque		Max Torque		Max Torque		Max Torque	
Dia / Pitch	lb.ft	Nm	lb.ft	Nm	lb.ft	Nm	lb.ft	Nm
M5 x 0.80	2	3	4.5	6	6.5	9	7.5	10
M6 x 1.00	4	5.5	7.5	10	11	15	13	18
M8 x 1.25	10	13	18	25	26	35	33	45
M10 x 1.25	20	27	39	53	57	78	66	90
M10 x 1.50	18	25	37	50	55	73	63	86
M12 x 1.75	33	45	63	85	97	130	111	150
M14 x 2.00	55	75	103	140	151	205	177	240
M16 x 2.00	85	115	159	215	232	315	273	370

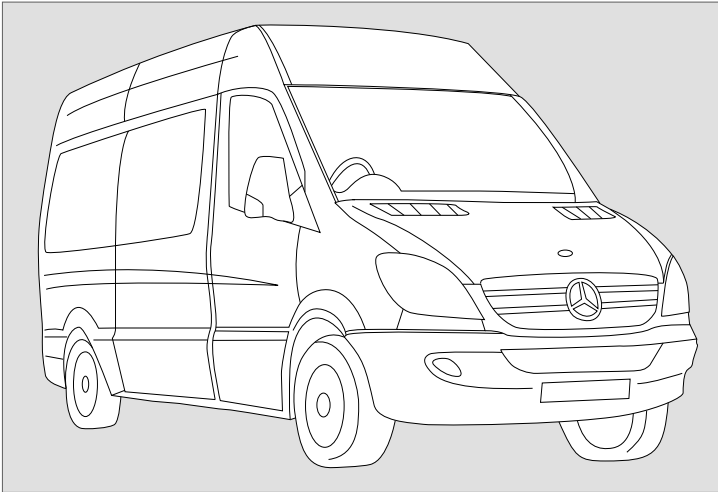

VEHICLE DETAILS

Manufacturer	Mercedes Benz
Make	Sprinter
Model	210 CDi / 214 CDi / 310 CDi / 314 CDi 510 CDi / 213 CDi / 313 CDi / 413 CDi 513 CDi / 216 CDi / 316 CDi / 416 CDi 514 CDi / 16 CDi BLUETEC E6
Engine CC	2148
Engine Details	OM651
Year	10.2009>
Chassis Nos.	N/A
LHD	YES
RHD	YES
PAS	YES
A/C	YES
Voltage	12v

KIT DETAILS

Kit Part No.	0500.8542
Description	Standard Kit
Compressor RPM	4695 @ Max Engine
Power Output	
Fitting Time	30 Minutes
Suction Fitting	90°
Discharge Fitting	90°
Belt Type	6PK 1250
Belt Part No.	0820.2241
Note	MB N63 Option Required

FOREWORD

The purpose of this manual is to facilitate the installation of a direct drive compressor. The information given is merely instructive, should any complications arise contact the Technical department. The manufacturer's warranty does not cover any problems caused by defective installation or alterations made unless authorised. The manufacturer shall not be responsible for any injury, damage or loss caused directly or indirectly as a result of using this manual or the information contained within it.

1 SAFETY MEASURES:

Before fitting the Compressor adapter drive kit, ensure the following for damage:

- a Inner and outer trim and body work
- b Engine idle pace
- c Check all the vehicle functions

Check list:

- a Ensure that the right kit has been selected
- b Before installing, check that all the correct pieces are present; also ensure that there are no missing or broken pieces
- c When fitting, make sure the vehicle is properly protected against damage.

Installation apparatus

- a Calibrated torque wrench
- b Hand service tools
- c Protective covers and shields

2 PRECAUTIONS

- a Detach the battery negative lead.
- b Torque all bolts where stated using a calibrated torque wrench.
- c Take extreme care with moving parts.
- d Remove the vehicle's ignition key and keep it with you.
- e Wear safeguards and make sure that liquid refrigerant never touches your skin

Caution: Measures must be followed accurately to steer clear of the possibility of damage to individuals

Warning: This calls awareness to actions which must be pursued to avoid damage to the components.

NB: This calls awareness to make the job easier or gives useful information.

PRE-INSTALLATION

N.B Prior to commencing work, please examine the instructions with care. The alphabetical symbols on the diagram relate to written instructions, numerical symbols relate to the parts listing.

Dismantle the following:

- Using a suitable TORX® drive, remove the original manufacturers idle pulley assembly and retain for future use ⑧ - Fig.1

COMPRESSOR INSTALLATION

- Mount a compatible compressor, specified on page 3 to the original manufacturers mount bracket A, using 2 x 8.4mm Spacers ⑥ between the rear ears of the compressor and the back mounting face of the mount bracket A, 2 x 1.6mm Spacers ⑤ between the front ears of the compressor and the front mounting face of the mounting bracket A, 2 x M10 x 130 bolts ⑪, 2 x flat washers ⑫ and 2 x Schnorr safety washers ⑬ - Fig 2

- Mount the original idle pulley ⑧ previously removed onto the tensioner bracket ① in the position shown - Fig 3
Torque bolt ⑧ to 25Nm / 18lbf using a calibrated torque wrench.
- Mount the supplied idle pulley ⑦ on to the tensioner bracket ① using bolt ⑨, draw bolt mounting block ②, washer ③ and M8 x 80 bolt ④ in the position shown. Leaving the idle pulley tensioner assembly loose - Fig 3.

- Mount the tensioner bracket assembly to front compressor ears, using the 2 x M10 x130 bolts previously fitted ⑪ Fig 4.
- Secure the tensioner bracket assembly to the mounting point for the original idle pulley, using bolt ⑩ M8 x 35 - Fig 4.

Torque bolts ⑪ to 50Nm / 37lbf using a calibrated torque wrench.

Torque bolt ⑩ to 25Nm / 18lbf using a calibrated torque wrench.

NB: Please refrain from using “Loctite” unless otherwise notified

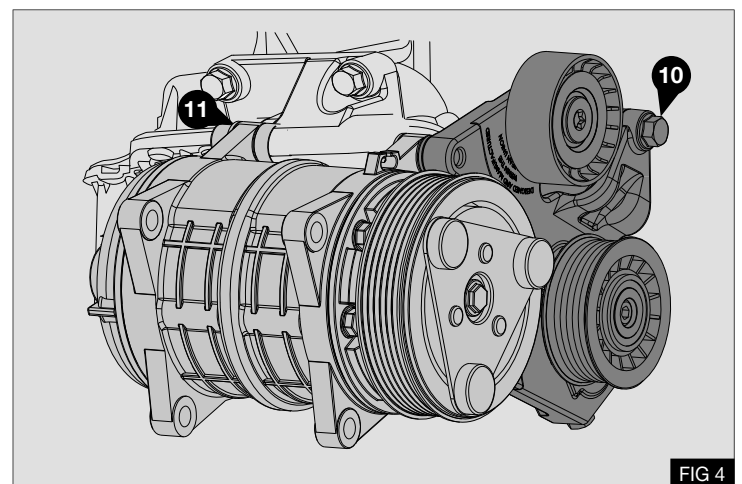
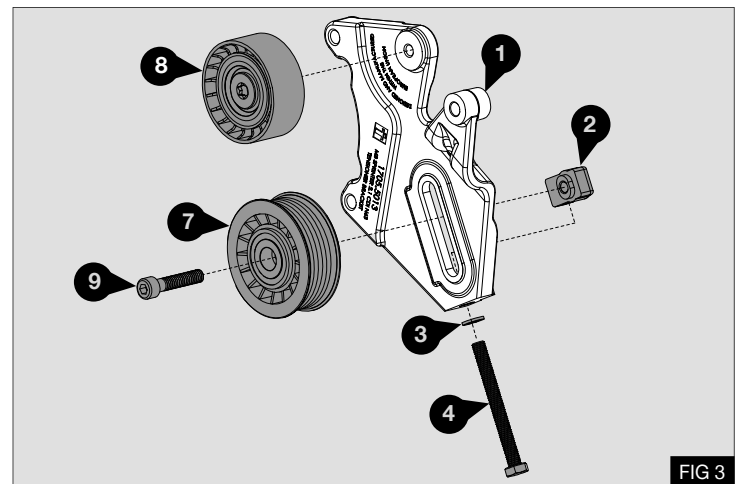
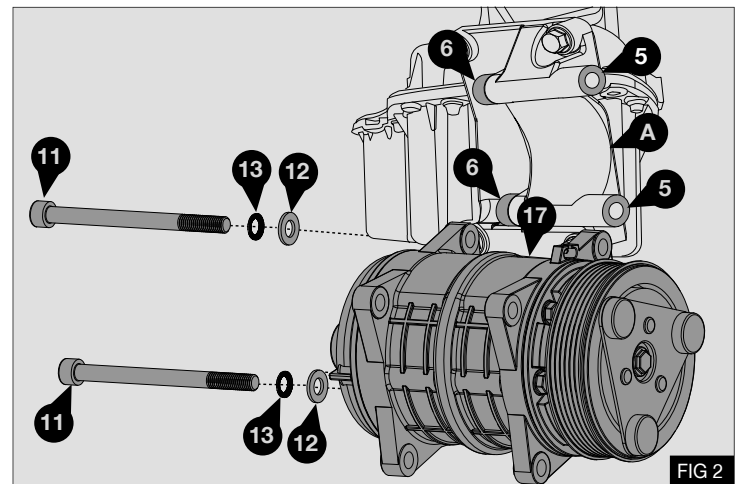
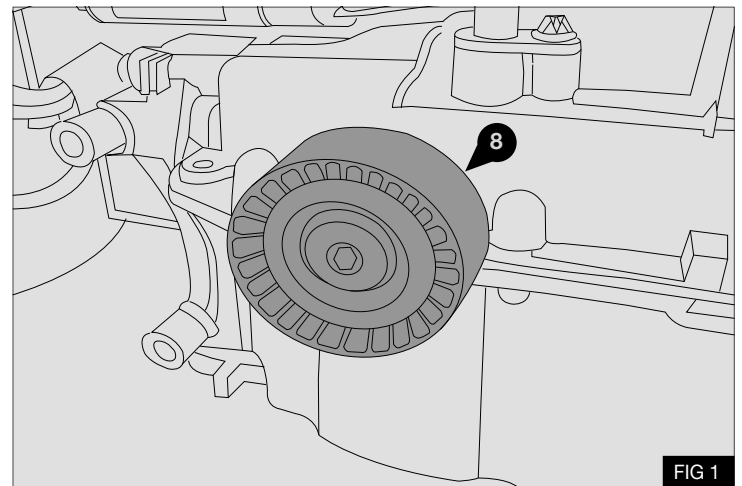

DRIVE BELT INSTALLATION

1. Fit supplied poly groove drive belt (14) - Fig.5

CP Crankshaft Pulley
TP Tensioner Pulley
IP Idle Pulley
RC Refrigeration Compressor

Tension the drive belt (14) using bolt (4)

Important: Fit the drive belt one groove back from the front of the compressor clutch (QUE/Valeo PV8) - Fig 7

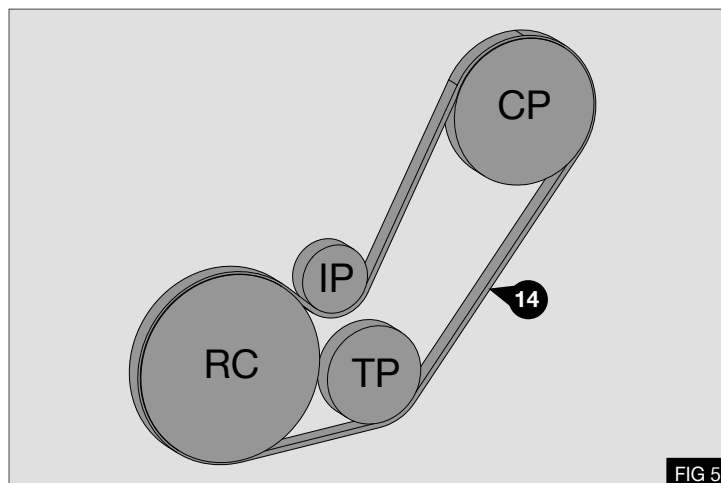

FIG 5

2. When correct tension has been achieved, tighten bolt (9) - Fig 6

Torque bolt (9) to 25Nm / 18lbf using a calibrated torque wrench.

POST INSTALLATION

1. Before starting the engine check all the installed parts and ensure that the belt is installed correctly. Run the unit for at least ten minutes, then check the whole mounting assembly and previously removed parts. Attach the supplied warning label (15) on to a suitable location.

NB: Check the belt tension when the belt is hot. It is important that the belt is allowed to cool before re-tensioning. Always re-tension new belts if the tension is less than the used belt amount.

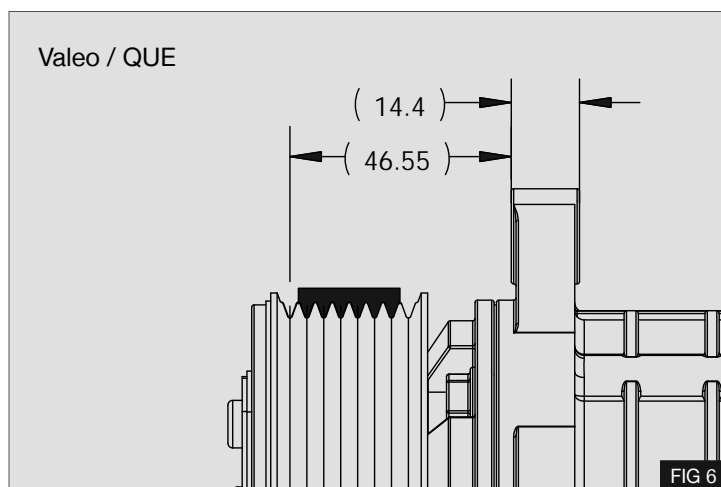

FIG 6

BELT TENSION TABLE

Belt	Belt Age	Belt Tension Using a Belt Tension Gauge
6 PK	New Belt	72 - 84 kg
6 PK	Used Belt / Re-Tension	54 - 60 kg

(EN)

Techni focuses on constant upgrading of its products. The Manufacturer reserves the right to modify the models and components described in the present publication at any time for technical or commercial reasons and without prior notice. For further information, contact Techni technical services.

(DE)

Techni ist stets bestrebt die eigenen Produkte zu verbessern. Die Herstellerfirma behält sich das Recht vor, aus technischen oder Verkaufsgründen, zu jeder Zeit und ohne vorherige Ankündigung, Abänderungen an den Modellen und den in dieser Veröffentlichung beschriebenen Einbauteile vorzunehmen. Für weitere Informationen bitten wir Sie, sich an unseren Techni Kundendienst zu wenden.

(FR)

Techni vise à une amélioration constante des ces produits. La maison se réserve le droit d'apporter, à tout moment et sans préavis, des modifications aux modèles et aux composants décrits dans cette publication pour des raisons d'ordre technique ou commerciale. Pour d'ultérieures informations s'adresser au service d'assistance Techni.

(IT)

Techni mira ad un costante miglioramento dei propri prodotti. La Casa si riserva il diritto di apportare in qualunque momento e senza preavviso modifiche ai modelli e ai componenti descritti in questa pubblicazione per ragioni di natura tecnica o commerciale. Per ulteriori informazioni rivolgersi al servizio assistenza Techni.

(ES)

Techni aspira a un constante mejoramiento de su producción. La Fábrica se reserva el derecho de aportar en cualquier momento y sin preaviso modificaciones a los modelos y los componentes descritos en esta publicación por razones técnicas o comerciales. Para ulteriores informaciones dirigirse al servicio asistencia Techni.

VENDITA E SERVIZIO
VENTE ET SERVICE

SALES AND SERVICE
VERKAUF UND SERVICE



Sundorne Trade Park, Henley Way,
Shrewsbury, United Kingdom, SY1 4NS
Telephone (+44) (0) 1743 443176
Fax (+44) (0) 1743 443113
Email: sales@techni.co.uk